

Manual Version 01

Make sure you have the latest support resources!

Visit ternbicycles.com/support for:



Weight Limits

- Do not exceed 25 kg (55 lb) when riding on paved roads.
- Do not exceed 12 kg (26 lb) when riding on graded and maintained gravel roads.*

* Riding off-road poses unique challenges. Reduce the max load by approximately 50% if riding on unpaved roads to ensure safety. Refer to the 'Intended Use' section in your bike's QuickStart Guide to learn more about suitable riding terrains.

What's Included

- Trail Rack
- SideStrap
- M5 x 16 Bolt x 2
- M5 x 40 Bolt x 2
- M5 x 10 Washer x 2
- M5 x 12 Washer x 2

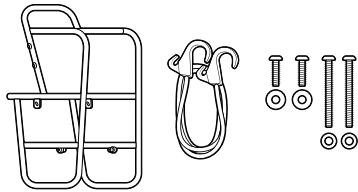

Installation

Tools Required (Not Included)

- 3 mm Allen Wrench

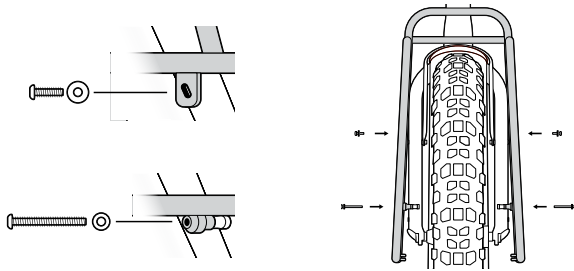

Tighten Bolts to a torque of 4 Nm - 5 Nm.

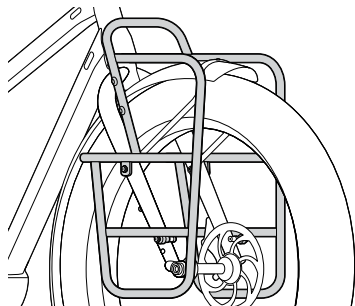

Safety

- ▲ Never exceed the Maximum Gross Vehicle Weight (MGVW) of your bike. The MGVW is the total weight of the bike, riders (the cyclist and any passengers), accessories, and cargo.
- ▲ The rack is strictly for carrying cargo. Do not transport passengers or live animals on the rack.
- ▲ Secure all cargo before riding. Take care that all straps are tied down and any loose items are secured.
- ▲ Check to ensure all accessories have been correctly installed and securely fastened before riding.
- ▲ Your bike may behave differently with a loaded rack.
- ▲ Place loads evenly on both sides of the rack.

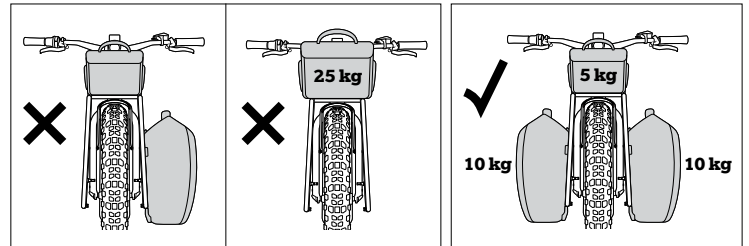

Maximum for Paved Roads

Installing a Bottle Cage (Not Included)

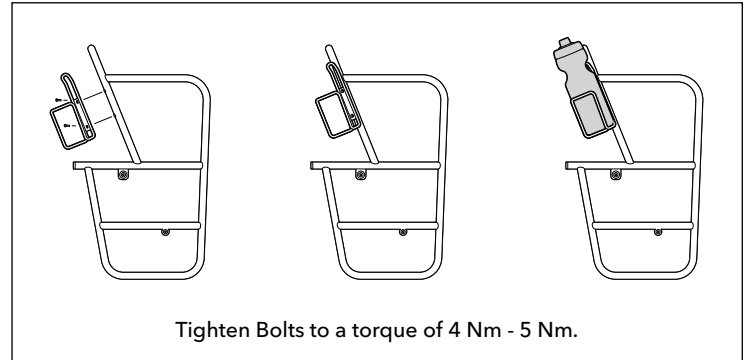

Tighten Bolts to a torque of 4 Nm - 5 Nm.

Tern, the Tern Werd (logotype), the Tern Berd (device), Orox, and Trail Rack used alone or in combination are trade names, trade devices or registered trademarks of Mobility Holdings, Ltd.

© 2024. Tern is a trademark of Mobility Holdings, Ltd. All Rights Reserved.

LIMITED PRODUCT WARRANTY INFORMATION: This Product comes with a ONE (1) YEAR Limited Warranty from the date of retail purchase by the original end-user. If a material or workmanship defect arises and a valid claim is received within the Warranty Period, this Product will be replaced. Mobility Holdings cannot be held liable for damages to personal property due to misuse or improper care and maintenance. This Product Warranty does not, under any circumstance, cover the replacement or cost of any third party product used with or connected to the Product.