

PHOTON GEN 2

User Manual

CYC MOTOR LTD
www.cycmotor.com



TABLE OF CONTENTS

SAFETY & PRECAUTION.....3

- General Safety 3
- Before the Ride..... 3
- Installation & Use 4
- Disclaimer..... 4
- Warning..... 5

TECHNICAL SPECIFICATIONS6

- Description 6
- General 6
- Parts List..... 7
- Dimensions..... 9
 - BSA Threaded 68/73/83mm Version (in mm)..... 9
 - BSA Threaded 100mm & BB92 Version (in mm) 10
 - BSA Threaded 120mm Version (in mm)..... 11

INSTALLATION 12

- Required Tools 12
- Operating Notice 13
- Preparing Your Frame 13
- Mounting Options..... 13
- Warning..... 13
- Motor Temperature Guidelines 13
- Adjusting the Width of the Bottom Bracket 14
- Torque Requirement for Bolts..... 15
- Assembly Instruction..... 16
- Wiring & Connection..... 21

MOBILE APP & DISPLAY22

GENERAL MAINTENANCE22

WARRANTY.....23



WARRANTY REGISTRATION..... 24
PURCHASES FROM A CYC DEALER 24
CONTACT INFORMATION..... 24
DISCLAIMER25
PRIVACY POLICY.....25
INFORMATION COLLECTION AND USE.....26



SAFETY & PRECAUTION

General Safety

Kindly read through the entire user manual. This manual contains important information to reduce user risk as well as instructions for this product's proper use. Do not discard the manual but keep it for reference.

Note that your personal safety remains your responsibility and that the user must contact CYC MOTOR LTD or their official product dealer/distributor directly for any further guidelines or assistance.

Never interfere with the movable parts when the drive unit is connected to a power supply. This could result in serious injury if the system is accidentally engaged.

This product is a powerful motor system that is dangerous for children and must be handled by an adult at all times. Small components and accessories may also present a choking hazard. Keep the motor system and accessories out of reach from children.

All components and accessories may only be replaced with identical components directly supplied by CYC MOTOR LTD or an official product dealer/distributor. CYC MOTOR LTD cannot be held liable for any damages as a result of using unapproved parts.

This product only complies with local, state, and federal regulations if speed limits are set accordingly. Ensure that you have set up your X1 Pro kit according to your local, state, and federal regulations when using and registering this drive unit on a public road/area.

Before the Ride

Ensure that the drive unit chain has the proper tension. Incorrect tension could cause jamming of the system and result in injury while riding. Inspect the chain tension regularly.

Ensure that the chains are properly lubricated. Cleaning and lubricating your chain with a regular bicycle chain cleaner, is advised regularly.



When plugging in your kit, please ensure that your peripherals are connected properly as faulty connection could result in damage of the controller or batteries.

Inspect all electrical wires and plugs for damage regularly.

Secure all wires properly. Ensure that the throttle can be twisted freely without friction and that the throttle can return to its original position without restriction. This is to prevent any uncontrolled response of the system.

Installation & Use

Only use the parts and accessories provided with this drive unit. Using other components may cause damage.

The system can be switched on or off by holding the ON/OFF button on the display.

Do not shift bike gears while the motor is providing power, as this can cause excessive wear or damage. Shift using pedal input only, then resume throttle or PAS after the gear change.

Always start riding with an appropriate assist level and bike gear.

The drive unit is splash and rain-resistant but not waterproof. Do not submerge or clean it with water jets or a pressure washer.

Disclaimer

If you need more information or have any questions about this user manual disclaimer, please reach out to us through our [Contact Us page](#).

All the information contained in this manual is published in good faith and for general informational purposes only. CYC MOTOR LTD does not make any warranties about the completeness of this information and encourages further inquiries if needed.

CYC MOTOR LTD will not be held liable for any losses and/ or damages in connection with the use of this product. **The use of this product is at own risk.**



Please contact CYC MOTOR LTD if you are unsure about the assembly instructions or for any further assistance as CYC MOTOR LTD will be held liable for any losses and/ or damages created by the assembly.

The control unit's hardware and software are under the GPL V3 open-source license. VESC® is a trademark of Benjamin Vedder. More information can be found at www.gnu.org/licenses/gpl-3.0.html. CYC MOTOR LTD's source code can be found at www.github.com/CYC-MOTOR. Different firmware can be loaded to this controller.

Warning

Any issues with this product's performance or damages sustained to the product as a result of loading unauthorized firmware, will not be supported, or warrantied by CYC MOTOR LTD or any authorised product dealer.

Modifications of any kind is not advised. Any issues with this product's performance or damages sustained to be the product as a result of modifications will not be supported or warrantied by CYC MOTOR LTD or any authorized product dealer. If the product or its components have been found to be modified, warranty of the product may be limited in the case where troubleshooting and/ or replacement may be needed.



TECHNICAL SPECIFICATIONS

Description

This product is a high-powered electric bike (ebike) drive unit kit which includes a programmed control unit and peripherals. This product is designed to be installed as a conversion system to convert standard bicycles into electric bicycles.

General

Rated Voltage	36V – 72V
Max. RPM at Crank	>300 RPM
Rated Power	250W / 750W
Peak Power	1200W (2000W in unrestricted mode)
Max. Torque at Crank	135 N.m.
Colour	Anodized Black
Weight of Motor Unit	3.5 kg
Total Weight with Crank set & Bottom Bracket	4.8 kg
Bracket Materials	7075-T6
Crank Arm Length	160mm / 170mm
Control Method	FOC
Motor Sensor	Hall & Temp. Sensor
Chainring	32T / 34T / 36T / 38T / 40T / 42T / 50T
Compatibility	BSA 68-83mm, BB92, BSA 100mm, BSA 120mm

*Bottom brackets not specified may be compatible. Contact CYC MOTOR LTD for more information before making a purchase if your bottom bracket is not listed above.



Parts List

Photon Motor Assembly	
Intuition Display	
SW102T Display	
Thumb Throttle	
Magnetic Wireless System Speed Sensor	
Speed Sensor Adapter	
Bottom Bracket Spacers	
(OPTIONAL) Magnetic Brake Sensors	



A-Frame	
Spindle Spacers	
BB92 to BSA adapters	
Crank arms with M15 crank arm bolts	
Left Bottom Bracket Cup	
Retaining Lock Ring	
Spindle	
Photon Gen 2 Chainring Set	



Dimensions

BSA Threaded 68/73/83mm Version (in mm)

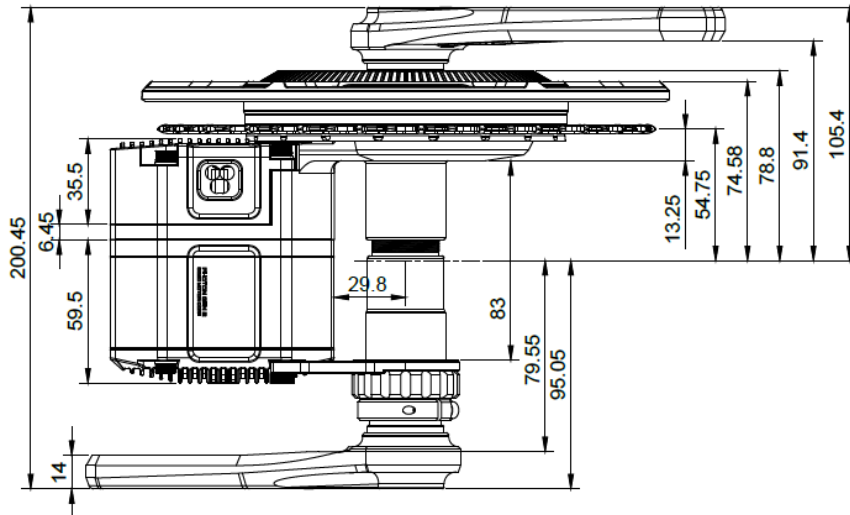
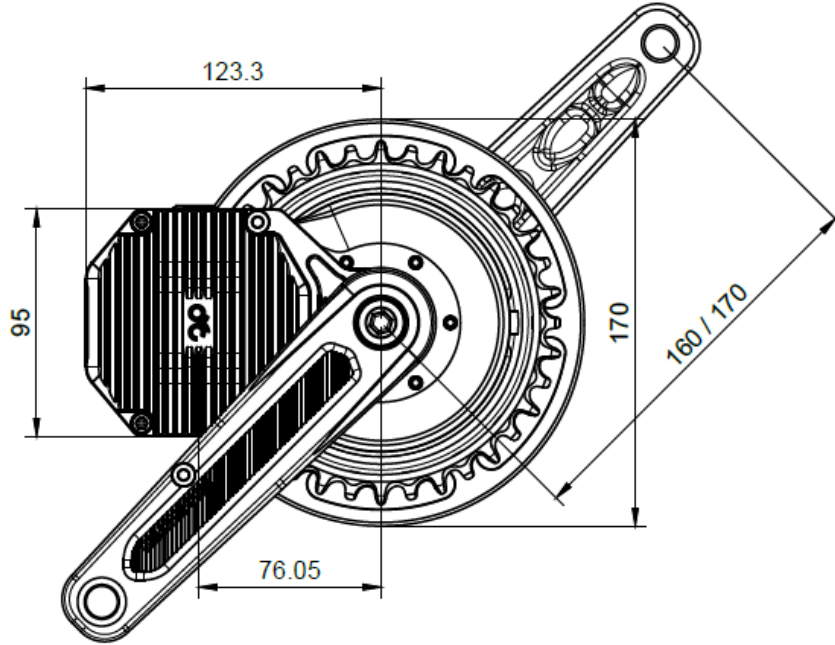



Dimensions

BSA Threaded 100mm & BB92 Version (in mm)

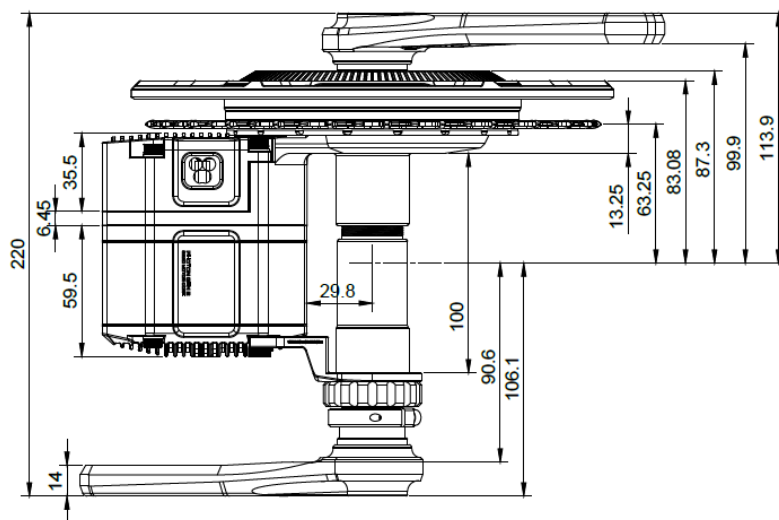
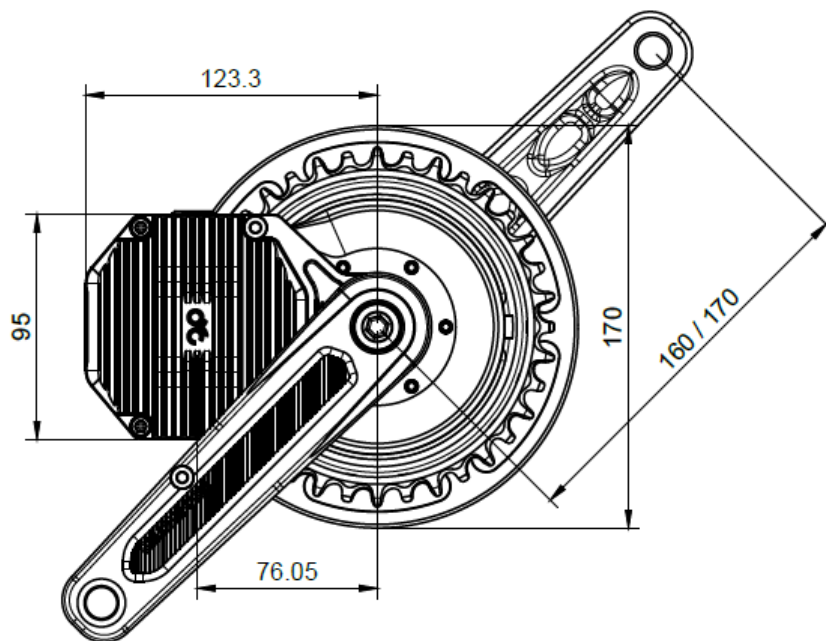



Dimensions

BSA Threaded 120mm Version (in mm)

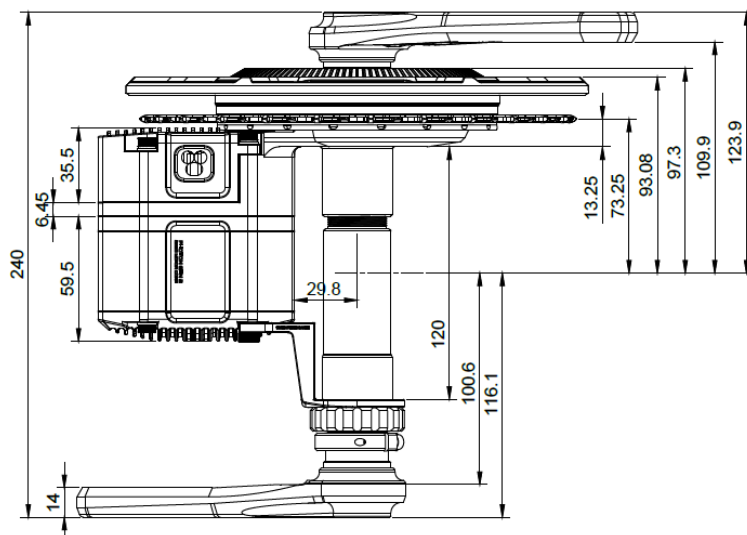
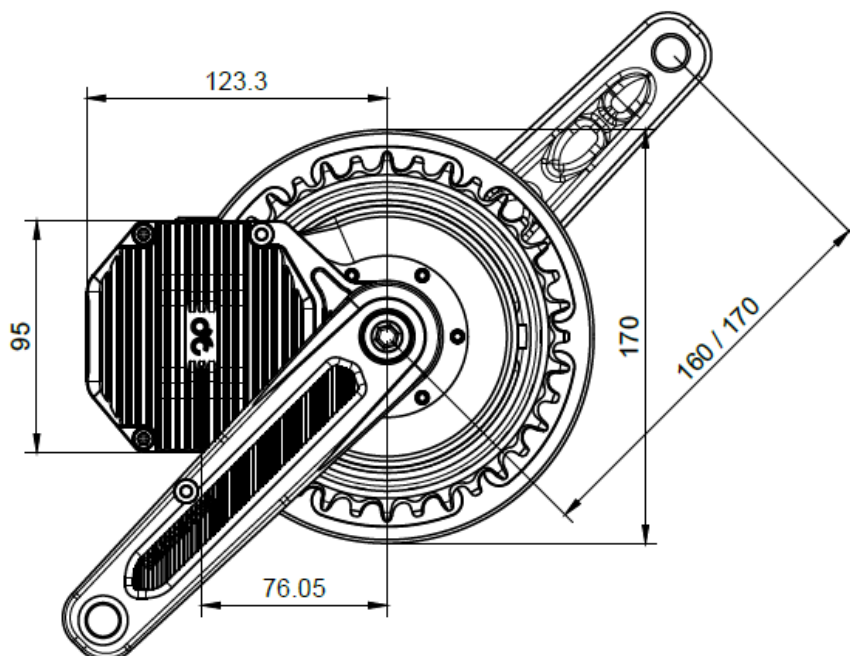



INSTALLATION

Required Tools

<p>Hex Keys (3mm & 8mm)</p>	
<p>Adjustable Wrench</p>	
<p>Crank Puller (for disassembly)</p>	
<p>PressFit Bottom Bracket Removal Tools (Only for BB92 version)</p>	
<p>16 Notch Bottom Bracket Tool</p>	



Operating Notice

RIGHT-HAND and LEFT-HAND sides are determined by the bike handle; Right-hand corresponds to the right handle.

Preparing Your Frame

Before you begin, ensure that you have removed the original crankset and bottom bracket from the bicycle frame. This includes any bearings, bottom bracket from the bicycle frame. This includes any bearings, bottom bracket ups, inserts, and/or adapters that might have been fitted. Clean up any grease and/or debris from your frame's bottom bracket shell and wipe off any excess dirt from your frame around the areas where the drive unit and its peripherals will be installed.

Mounting Options

This product can be mounted in any position around the bicycle frame's bottom bracket shell that supports the drivetrain's movement without obstruction. The chainring assembly together with your bicycle chain must be able to move freely and not come into contact with other components or areas on the bicycle frame.

Warning

The motor body must be supported against either the bicycle frame or supporting structures in order to prevent the motor body from movement during use.

Carefully thread in the bottom bracket slightly and insert the spindle to ensure proper alignment. **DO NOT** force threads! Add grease on threads and spindle.

Motor Temperature Guidelines

The Photon Gen 2 motor features a different temperature profile compared to our previous motors. Key points to note:

- The motor can safely reach up to **150 °C** under extreme conditions.



- To ensure longevity and safe operation, the motor is **programmed to limit maximum temperature to 120 °C**.
- Temperature-based power reduction will **begin at 100 °C**, gradually reducing output to prevent overheating.

Always monitor your motor temperature during extended rides, especially in hot environments or under heavy load. This ensures optimal performance and protects the motor from damage.

Adjusting the Width of the Bottom Bracket

In order for the CYC kit to fit on various different widths of bottom brackets, there are several spacers that come with the kit. These spacers are designed to provide the bottom brackets with necessary spacing between the motor brackets.

Please note that the spacers can be adjusted to accommodate different chainlines as needed.

The preferred mounting set-ups are shown on the next page for 68mm and 73mm bottom brackets.

Before you begin, ensure that you have removed the original crank set and bottom bracket from your frame. This includes any bearings and/or cups that might have been fitted previously. To install your CYC kit, you will need a clean bottom bracket shell on your frame.

Bottom Bracket Version	Q Factor	Chainline	Spacer on Left	Spacer on Right	Centre Offset
BSA 68mm	200	~50	5 + 7	3	0.65
BSA 73mm	200	~50	3 + 7	0	0.18
BSA 83mm	200	~55	0	0	5.18
BB92	220	~63	0	0	3.9
BSA 100mm	220	~63	0	0	3.9
BSA 120mm	240	~73	0	0	3.9



Torque Requirement for Bolts

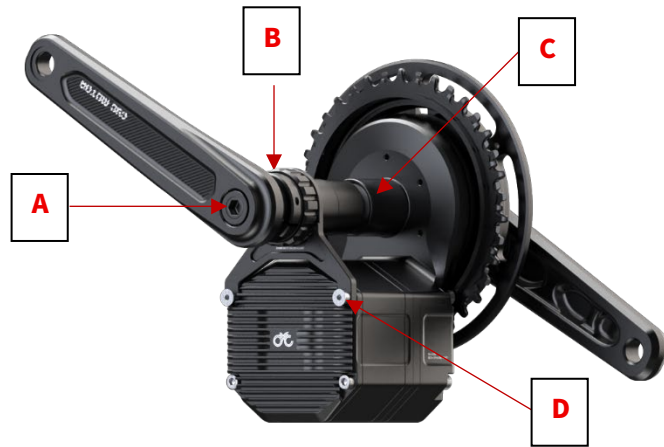

Listing	Part Name	For	Torque Requirement
A	M15 Crank Arm Screws	Crank arms	55 N.m.
B	Lockring	Lockring	Tighten by hand
C	Left Bottom Bracket Cup	Left Bottom Bracket Cup	40 – 50 N.m.
D	Shoulder Screw, M5x6x15 (Hex H3)	A-Frame	3 N.m.



Assembly Instruction

1. Insert the motor into the drive side of the bottom bracket, adding spacers if needed.

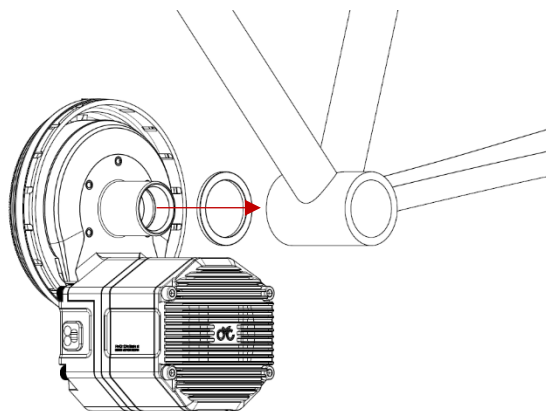

2. Ensure the motor is fully into the bottom bracket and sits flat against the bottom bracket opening. Take note of the clearance between of the chainstay of the bike and the motor unit is **13mm**.

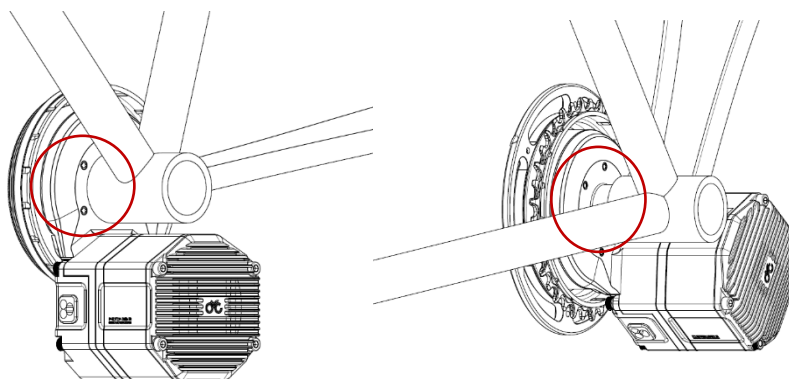

3. Ensure proper clearance between the motor unit and chainstay, For bottom bracket narrower than 83mm, use the provided spacers and optionally a 0.5mm spacer for frame tolerance. Apply grease before threading in the bottom bracket. (See [page 14](#) for spacer guide).

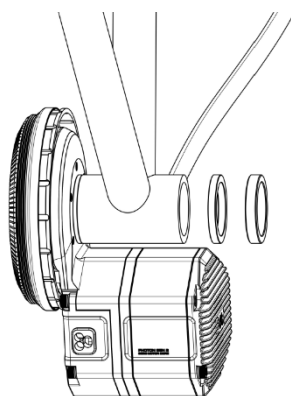

4. Insert the left bottom bracket cup with the required spacers, making sure the A-frame lines up with the motor housing cutout. Use a bottom bracket tool to tighten the bottom bracket lightly, then insert the two M4 screws in the motor housing and tighten accordingly. (3 N.m.)

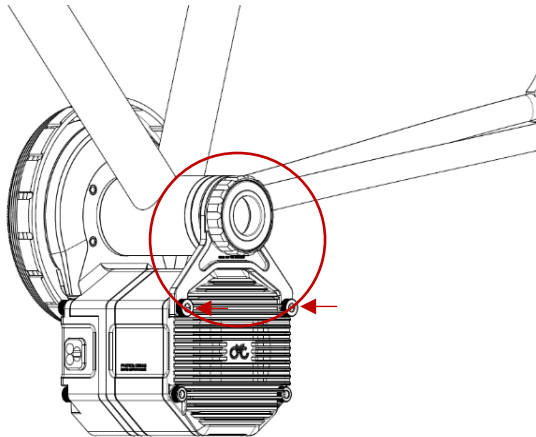

5. Pivot the motor to the desired position and tighten the bottom bracket cup to the specified torque (see [page 15](#) for torque specification). Install the frame support plate if needed. **Ensure the bottom bracket cup is perfectly straight before final tightening.** Misalignment can cause premature bearing wear and noise.

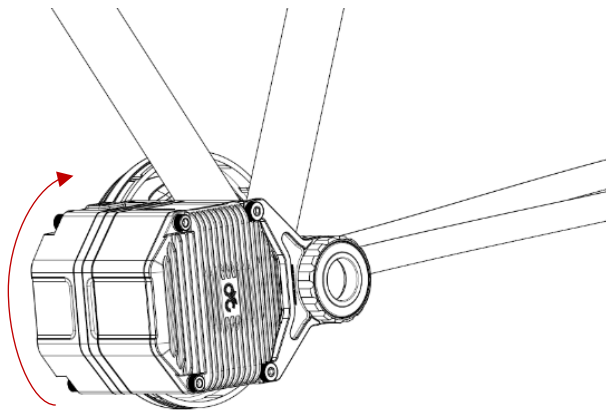

6. Insert the spindle through the motor, align the splines, apply grease, and gently tap it in with a soft mallet until the shaft step contacts the motor. Before final tightening, **ensure the spindle is straight and secure**. Misalignment can cause premature bearing wear and noise.

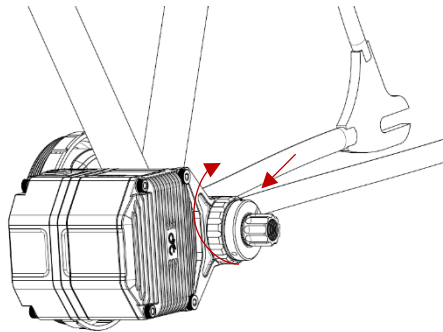

7. Thread the lock ring onto the spindle, with step on the lock ring facing towards the bike. Tighten by hand and then tighten the crew on the lock ring. **Ensure that the spindle can rotate freely**.

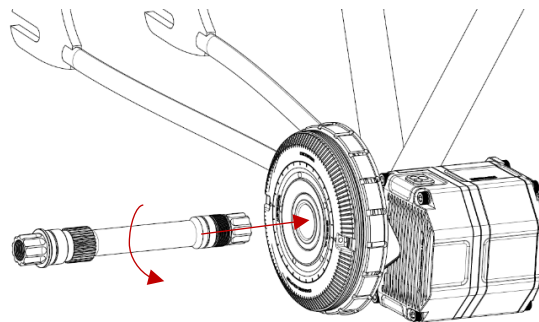

8. Install spindle spacers up to the indicated line. Adjust as needed based on your bottom bracket width, as tolerances vary.

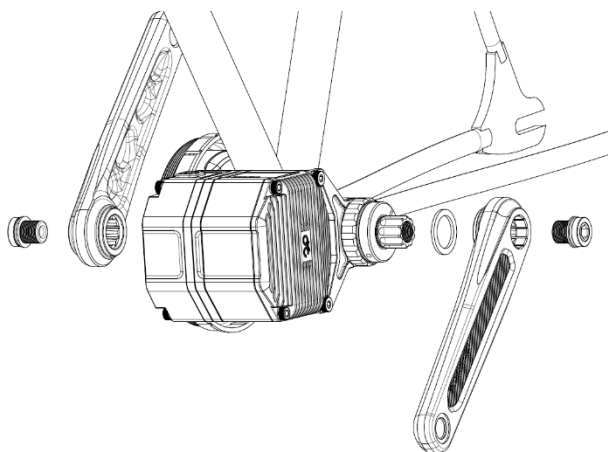

9. Install the crank arms and tighten the M15 crank arm bolts (55 N.m.) using an M10 hex key. Tighten to torque specification (see [page 15](#) for torque specification).

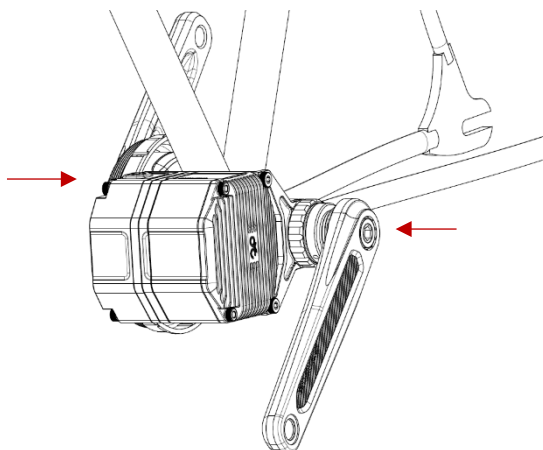

10. Assemble the chainring, spacer and chainring cover in order. Make sure the larger side of the spacer faces the motor body.

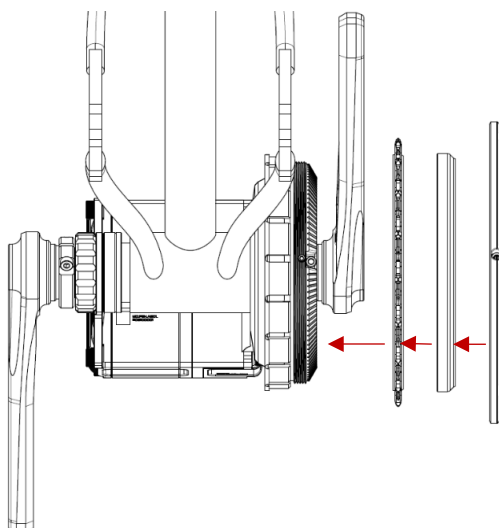

11. Place the chainring onto the Photon motor body, ensuring the side with the dot faces away from the bike.

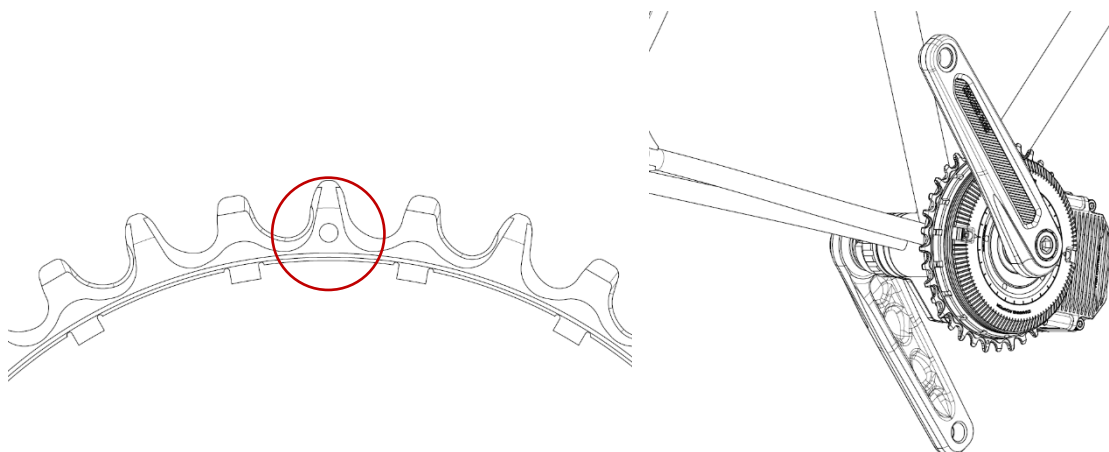

12. Position the chainring spacer with the thicker side facing the motor, then slide it over the Photon motor body.

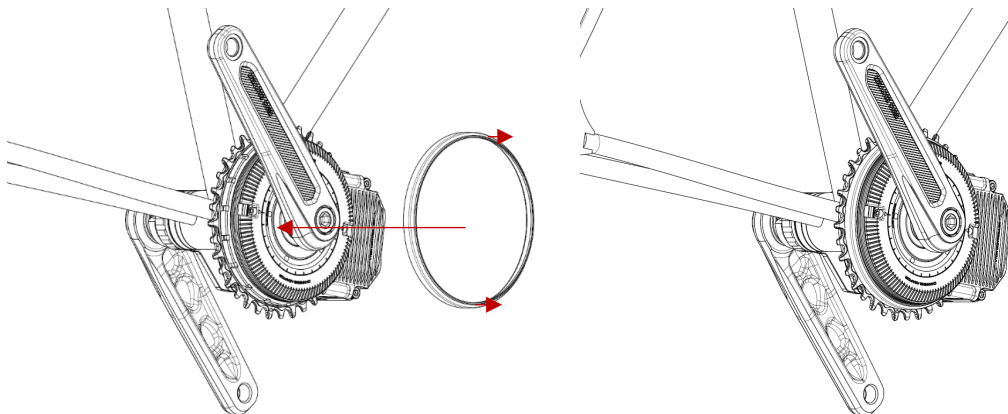

13. Apply grease to the inner threads of the chainring cover, thread it onto the Photon body, and finally tighten it using the provided V-shaped tool.

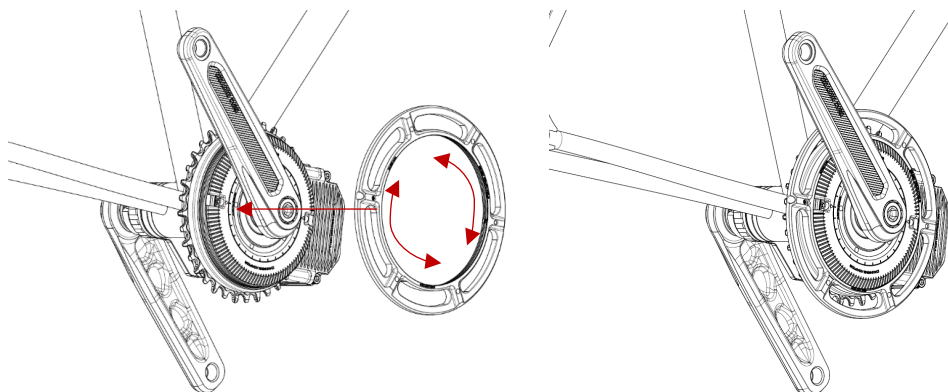

14. Secure the chainring cover by tightening the two grub screws (2.5 N.m) on either side.

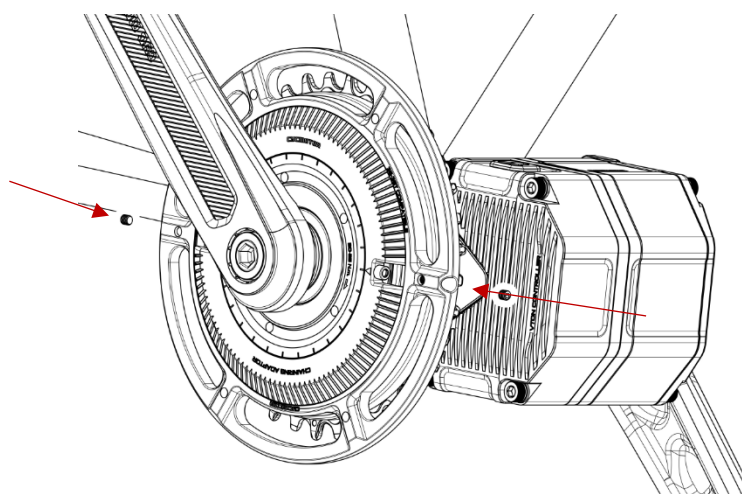



Wiring & Connection

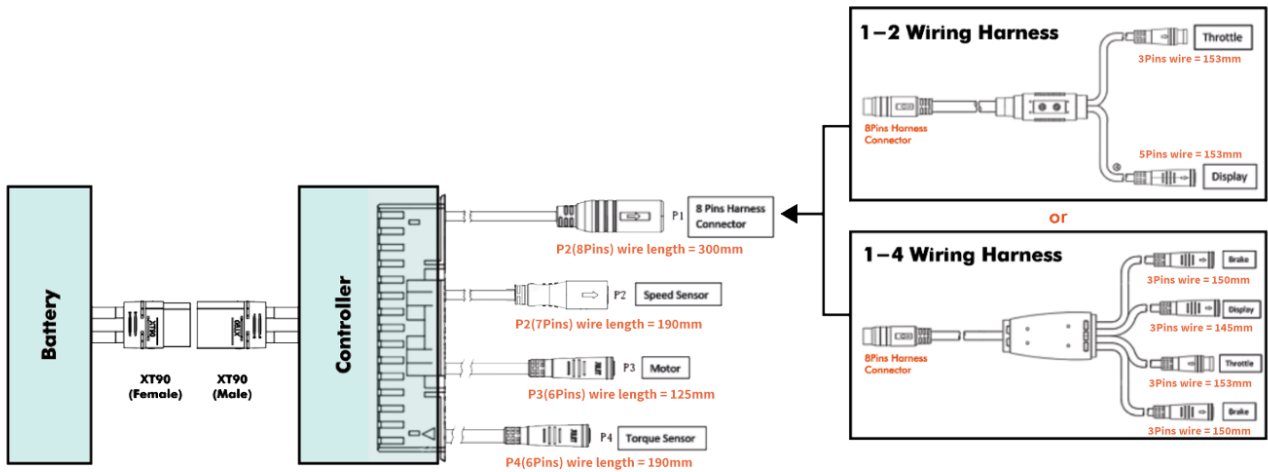

Connect your controller to the following connectors as per below:

1. Connect the peripheral connector (P1) to the 1-2 or 1-4 wiring harness
2. Connect P2 to the speed sensor

For brake sensors:

Please note that if you purchased brake sensors separately, you will need to enable them on the CYC Ride Control app. If the sensors are from another supplier, ensure the connectors match. A pin-layout may be requested through our [Contact Us page](#).

MOBILE APP & DISPLAY

Download the **display** and **mobile app** user manuals from the link below or by scanning the QR code. All materials listed below are freely available for download on our website.

<https://www.cycmotor.com/cycdownloads>

Included in the **downloads** page:

- Instruction Card
- User Manual
- Ride Control App User Manual
- Intuition Display User Manual
- SW102T Display User Manual
- Speed Sensor Installation Guide
- Brake Sensor Installation Guide
- 1.1 printouts for mounting reference
- And much more!



GENERAL MAINTENANCE

You are advised to regularly maintain, clean, and check the status of the bike and motor system as dirt will accumulate throughout the rides and additional strain will be taken by the drivetrain due to the powerful motor system. We recommend that users should inspect the bike and motor condition before and after each ride.

Disconnect all power supplies from the drive unit before starting any work (e.g., inspection, repair of the bike, maintenance work etc,) on the bike, transportation, or storage. Unintentional activation of the drive could lead to serious damage or injury.

Never reach into the chains, gears, or any moving parts while the bike is still in operation.

As the drive unit can get hot after use, be sure to give it some time to cool down before performing any maintenance.



Store the bike in a cool and dry place, sheltered from direct sunlight and potential rain.

Do not attempt to disassemble or modify the drive unit. The drive unit may only be repaired and maintained by qualified experts and only replaced with original spare parts. This will ensure that the safety/warranty of the drive unit is maintained.

The active moving parts (e.g., chain, gear, speed reducer etc.) should be regularly lubricated to maintain desired performance. In case of any abnormal activity, stop using the drive unit immediately and contact your CYC dealer.

Do not attempt to replace the product parts with the parts that have been found at a local bicycle store as the materials used in the drive unit are specifically designed for their purposes.

All bolts, nuts and screws are required to be tightened to the correct torque, if there is anything loose, stay off the bike. Torque specifications for each bolt and nut is provided.

WARRANTY

This product comes with a 1-year warranty, starting from the date of delivery. A warranty registration card is included in the package.

Please note that the warranty does **not** cover damages resulting from accidents, misuse, abuse, neglect, improper installation, modification, normal wear, or the use of non-approved parts. Man-made failures are also excluded.

For detailed information, please refer to our [Returns & Refunds policy](#).

Extend your warranty to 2 years if purchased and used with a CYC battery pack. Extended warranties need to be registered through the Warranty Registration card included in your kit upon delivery.

Extended warranties may also apply to approved third-party batteries from authorised resellers. Contact an authorised reseller for more information.

WARRANTY REGISTRATION

Register for warranty by scanning the QR code below and submitting the form or via the link below:

[Warranty Registration Form](#)



PURCHASES FROM A CYC DEALER

CYC authorized dealers may have their own terms and conditions. If you experience any issues with your item(s) and did not purchase the kit directly from us, please contact the dealer you bought from for assistance.

If you'd like to find a CYC dealer near you, or if you're a dealer or distributor interested in becoming an authorized partner, visit cycmotor.com/dealers.

CONTACT INFORMATION

For customer support, including shipping, quotes, tax, and sales -> support@cycmotor.com

For technical assistance, including build assistance, recommendations, troubleshooting, and product related queries -> technical_support@cycmotor.com.

OFFICE HOURS

Monday to Friday

9AM – 6PM (Hong Kong Time HKT)



DISCLAIMER

The electric bicycle system described in this user manual is designed for converting a bicycle only. It is important to read and understand this manual before using the system.

The manufacturer of this electric bicycle system will not be held liable for any direct, indirect, incidental, or consequential damages that might arise from the use or misuse of this system. Users are solely responsible for their safety while operating their electric bicycles and assume all risks associated with the use of this system.

PRIVACY POLICY

CYC MOTOR LTD strives to provide the best ebike & emtb experiences through our mid-drive electric bike conversion kits, adhering to the highest standards of industry ethics. We encourage you to read our Privacy Policy for more details.

CYC MOTOR LTD developed the CYC MOTOR LTD apps, including the RISTRETTO 303 FS and CYC Motor (BAC) app, as free services. These services are provided by CYC MOTOR LTD at no cost and are designed for use 'as is.' The RISTRETTO 303 FS and CYC Motor (BAC) apps gather location data to facilitate wireless device searching following the ASI controller's protocol. Please note that we do not upload or track your location data.

This page aims to inform visitors about our policies concerning the collection, use, and disclosure of Personal Information for those who decide to use our Service.

By choosing to use our Service, you consent to the collection and use of information in accordance with this policy. The Personal Information we gather is employed for providing and enhancing the Service. We will not use or share your information with anyone except as described in this Privacy Policy.

The terms in this Privacy Policy have the same meanings as in our Terms and Conditions, accessible at CYC MOTOR LTD, unless otherwise specified in this Privacy Policy.



INFORMATION COLLECTION AND USE

To enhance your experience while using our Service, we may need you to provide us with certain personally identifiable information, such as your name (optional), phone number, email address, and location (optional). This information, once collected, will be retained, and utilized as outlined in this privacy policy. Please be aware that our app uses third-party services that may collect information used to identify you.

Please visit www.cycmotor.com/privacy-policy for more detailed information.